

## ISM-8000

### Features

- 8-channel multiplex light barrier with modulated infrared light
- Range up to 60 m
- Menu-driven operation via display
- Manual / automatic operation selectable
- Permanent sensor monitoring
- Test function
- Switching ON and OFF delay adjustable
- Switching output 60 V / 100 mA, floating distance
- Alarm output for power limit
- Test input for external test equipment
- Sensor connections are short circuit proof
- Master-Slave mode
- Mounting for DIN rail EN 60715

### Short Description

Light barrier amplifiers are used for the detection of objects in machines or production systems. They form, in conjunction with one infrared transmitter and receiver a powerful light barrier and they are useable in areas with a long range or an extreme degree of pollution in which traditional light barriers reach their limits.

The modulation of the infrared light will additionally give the system a high degree of immunity to ambient light, disturbing impulse and influence from other light barriers. The amplifier is equipped with an automatic power adjustment, with which the transmit power adjusts to the special environments of the application.

To increase the overall accuracy of the device, permanent sensor monitoring was included, which detects errors at the sensor heads and signals this to the user by the alarm output. The exact error cause, short circuit or broken wire at the transmitter or receiver, may also be read on the display.

A floating distance switching output reports the light beam status to an evaluation unit, (e.g. a PLC). Included as extra equipment is the integrated test input with which it is possible to make an examination of the light barrier system's functionality.

If more than 8 channels are necessary a synchronized operation, to prevent influences between the channels form additional devices, is possible by connecting the master-slave connection.

As a special feature, the device includes a serial interface for easy operation with a PC (Software is optional available).



### Safety Instructions



#### Warning!

The infrared light barriers ISM-... are not safety systems and should not be used as such systems.

The devices are not to be used for applications, where personal safety is dependent on their function.

### Device Overview

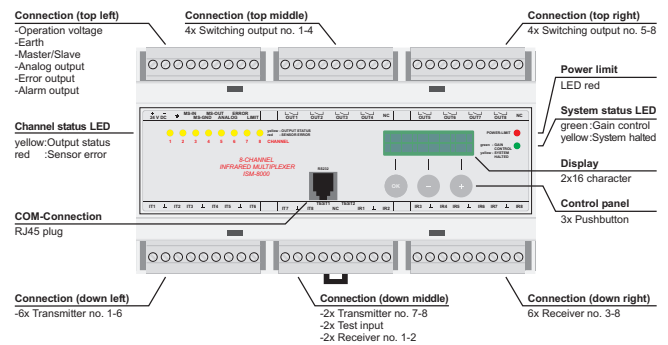

### Ordering Table

Type	Order code
ISM-8000 pluggable	ISM-8000/24VDC
<b>Accessories</b>	
Communication cable	CAB-COM-2m
Power supply unit 95...265 V AC	PSU-1000S/95-265VAC
Protective enclosure	PanBox 1x8

## ISM-8000

### Technical Data (at 20 °C / 68 °F, 24 V DC)

Operating voltage	24 V DC / ±20%
Power consumption (max.) <sup>1</sup>	4,6 W
Power loss (max.) <sup>1</sup> (EN 61439)	4,6 W
Operating basis	modulated infrared light
Transmit frequency	4,0 kHz
Transmit power	manual / automatic
Basic transmit level	low / high
Switching behavior	light / dark
Multiplex speed	34 ms
Switching delay	0...60 s
MTBF (IEC 61709)	5,0 · 10 <sup>5</sup> h (T <sub>a</sub> = 40 °C / 104 °F)
Operation temperature	0 °C ... 50 °C (32 °F ... 122 °F)
Storage temperature	-10 °C ... 60 °C (14 °F ... 140 °F)
Housing material	NORYL (self-extinguishing)
Protection class (EN 60529)	IP20
Mounting	top hat rail EN 60715
Electrical connection	screw terminal, pluggable 0,14 - 2,5 mm <sup>2</sup>

Switching output	NO (semiconductor relay) floating distance, short circuit proof	
Switching data (max.)	100 mA / 60 V AC (DC)	
Reaction time	36 ms	
Alarm output	pnp, 24 V DC	
current carrying capacity	100 mA	
Error output	pnp, 24 V DC	
current carrying capacity	100 mA	
Test input	max. 30 V DC / 2 mA	
response voltage	Low < 5 V DC; High > 15 V DC	
Analog output	0...10 V DC or 10...0 V DC	
COM interface	RS232	

max. Range (through beam)	Receiver IRL-...	Receiver IR-..., IRH-...
Transmitter IT-..., ITL-...	10 m (33 ft)	15 m (49 ft)
Transmitter IT-...HP, ITH-...	12 m (39 ft)	25 m (82 ft)
Transmitter ITA-...	25 m (82 ft)	60 m (197 ft)

<sup>1</sup> Without loads at the outputs

### Connection Diagram

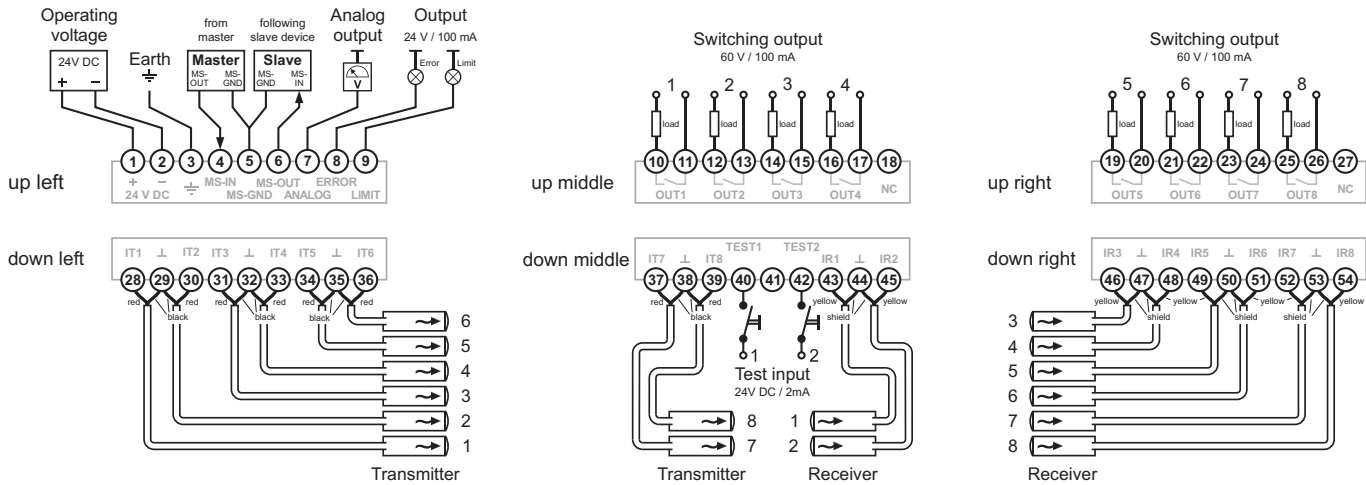

### Dimensions (in mm)

